

2024

Product Catalog



Lighting Your Savings

Lighting Your Success

EAGLE SQUARE
LIGHTING & ELECTRICAL

EAGLE SQUARE LIGHTING & ELECTRICAL



Operating as a 100% Australian owned company, your premier destination for high quality LED lighting solutions.

With a commitment to excellence and innovation, we have established ourselves as a trusted partner for businesses across Australia, delivering exceptional value and efficiency through our extensive product range and fostering long term relationships with our dedication to quality customer service.

Being a new and ever growing lighting and electrical wholesaler with a head office based in Brisbane, and a strong supply chain, we can safely say that we have a blueprint for Brisbane's Olympic Games in 2032 as we support the construction industry in its preparation.

Why Choose Us?

- Quality and Savings:** We source our LED lighting solutions from reputable manufacturers, ensuring that every product meets stringent quality standards. We aim for saving every penny for our customers, at the meaning time keep the high quality standard of our products and send them to our customers on the right time.
- Personalized Service:** Your success is our priority. We work closely with you to understand your objectives and challenges, crafting lighting solutions that align with your goals and budget.
- Unparalleled Expertise:** With years of industry experience, our team of experts is well-equipped to provide tailored lighting solutions that cater to your specific business needs. Whether you're looking to upgrade your existing lighting or embark on a new project, we're here to guide you every step of the way.
- Sustainability: By choosing** LED lighting, you're making a positive impact on the environment. LED technology is energy-efficient and environmentally friendly, reducing your carbon footprint and contributing to a greener future.

At Eagle Square Lighting and Electrical, our target is to be a leader in the building and general electric industry while we demonstrate our business rules which are as follows..

Innovation - Striving to stay ahead of the curve on new product development with the growing tagline "If it doesn't exist yet, have it made!"

Diversity - We believe in treating each person with the same level of respect regardless of ethnicity, gender, age, social background and or sexual orientation.

Accountability - At Eagle Square, if we make a mistake, we clean it up with a team dedicated to solving problems, not complaining about them.

Passion - With a highly dedicated team, we are passionate in building something special here that not only brings us a win but brings a win to all that we service with our hard work and tenacity.

ABOUT US	01
LED LIGHT	02
Downlight	
Highbay	
Panel Light	
Flood Light	
Oyster Light	
strip Light	
Track Light	
Wall Light	
Batten	
Globe	
Street Light	
Sport Light	
EXTERIOR	03
Ceiling Light	
Gu10 Pillar	
Bunker Light	
Inground/ Deck Light	
E27 Bollard	
EXIT & EMERGENCY	04
Exit Light	
Emergency Light	
SMOKE ALARM	05
CCTV	06
LIGHTING ACCESSORIES	07
ELECTRICAL ACCESSORIES	08
POPULAR PRODUCTS	09
HIGH-MAST & STREET LIGHT	10

LED LIGHT

Downlight



TL 70MM-210MM



ES 90MM-180MM



UGR19



Low Glare



Anti Glare P



Anti Glare M



Low profile large



Low profile Gimble



Gimble Downlight



Surface 3k or 5k



Surface CCT Adjustable

Highbay



HB01 5700K



HB01-Sensor



HB02 5700K



HB02
3 Power, 3CCT
3/4/5.7K

Panel Light

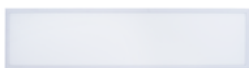

3CCT Panel 3/4/5.7K
Rectangle & Square

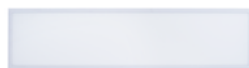

3CCT Panel 3/4/6K
Rectangle & Square

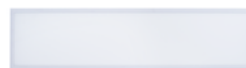

Panel 5K
Rectangle



Panel 6.5K
Square

LED LIGHT

Flood Light



FL01 5000k



FL01 3000k



COMBUS 5700k

Oyster Light



GU-OYSTER



LS-A-SLIM



LS-S-OPAL



CE-Surface

Strip Light



ES COB
3k or 5k

LED LIGHT

Track Light



ESTL01
3K in black
4K In White



TL3CCT
3/4/6K

Wall Light



TL 13w*2 C



CE 15W*2 F

Batten

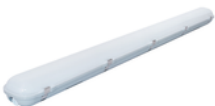

ES-IP65



LS-BAT002



LS-RAZORDMW02



LS-H-VISTA



LS-S-9732

LED LIGHT

Globe



T8



GU10



MR16



B22



E27

Street Light (Special Order)



ES-ST01
50W-300W

Sport Light (Special Order)



ES-HS
250W-1250W

Exterior

Ceiling Light



Opal IP65 Round



Opal IP65 Convex

GU10 Pillar (316 SSL/ White / Black)



IP65 S
Adjustable



IP65 D Adjustable



IP65 D Fixed



IP65 U/D Fixed

Bunker Light



Oval Bunker
3k or 5k
Black/White



LS-A-Bunker Tri
Black/White



LS-A-Bunker 4K
Black/White

Exterior

Inground Up/ Deck Light



LS-DECK01

E27 Bollard



LS-Louvered



LS-Elanora

Exit & Emergency

Exit Light



Economy



Switchable Clever
Black/ White



R Blade



Blade



Box CM



Box WM



40 JUMBO



IP65 WM BOX

Emergency Light



Economy D32



Premium D40
Black/White



Premium D80



Premium D40 SM
Black/White



Premium D80 SM



Premium IP65
D40 SM



Emergency Batten



Emergency Flood



Emergency Oyster



Emergency Bunker

Smoke Alarm



240v with 9v battery back-up



240v with rechargeable lithium battery



10 years lithium battery stand-alone



10 years lithium battery RF wireless

CCTV



T261



T269



T281



D261



NVR 4-16 Channel



Surveillance Hard Drive



Cat6

Lighting Accessories



Downlight
90MM Ring



Highbay
Bracket



Highbay
Acrylic Reflector



Highbay
Aluminum Reflector



Highbay
Milky Diffuser



Highbay
60D Len



Panel Frame
Surface Mount
optional screw free



Panel Frame
Recessed



Panel
Suspension Kits



Track Light
1/2/3m Track



Track Light
Suspension Kit



Track Light
Straight Joiner



Track Light
T & L Joiner



Track Light
End & Flexibale

Electrical Accessories

Switches & Power point



Equivalent
2000 Series
1-6 Gnag



Equivalent
2000 Series
GPO



Classic Slim



Classic Slim GPO



WPGPO

Electrical Accessories



QC413



PB70



JBS



JBL



SSC



DSC



CHT RCBO



DIM



Sensor R



Sensor SM



V Nail



H Nail



Half Saddle



Full Saddle



C Clip



Cable Tie



Cable Clip



Flex & Plug



MD Conduit 25m



TPS+E 1.5



TPS+E 2.5

Features

- Triac dimmable
- Input voltage range: 220-240V 50/60Hz
- Housing: aluminium & plastic
- Built in driver
- CCT selectable:3000K,4000K, 6000K
- CCT switch on rear
- Diffuser: frosted PC
- Polyamide body with latest heat dissipation technology
- Power factor: 0.9
- Ambient temperature:-20°C~+45°C
- High efficiency SMD LED chips 100lm/w
- IC-4
- Flex & plug: 1m
- CRI ≥80 and good stability over lifetime
- Quick and simple installation, with flex and plug
- IP44 below ceiling
- 3 years warranty option for 70mm & 90mm
- 5 years warranty 90mm to 210mm



Dimensions

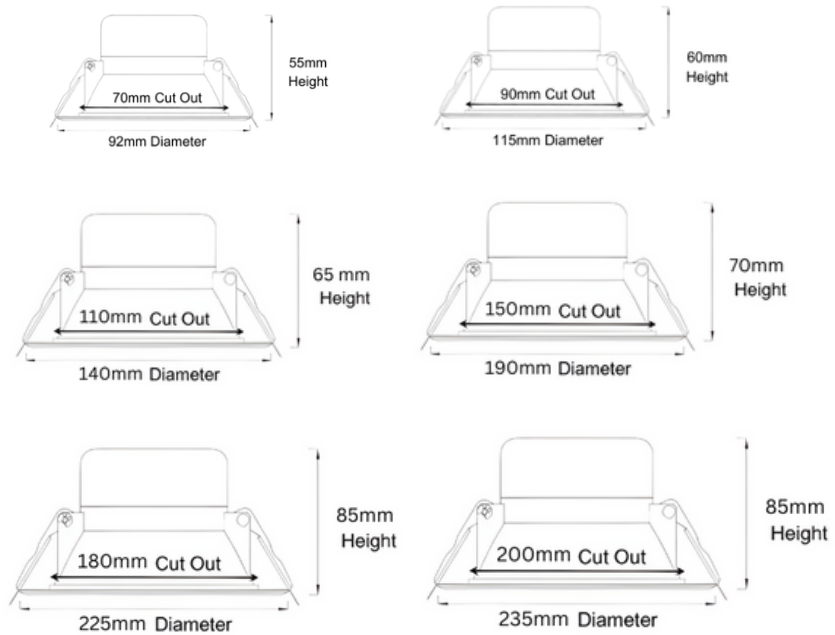

Standards

- IEC/AS/NZS 60598.1
- IEC/AS/NZS 60598.2.1
- IEC/AS/NZS 60598.2.2
- IEC/AS/NZS CISPR 15

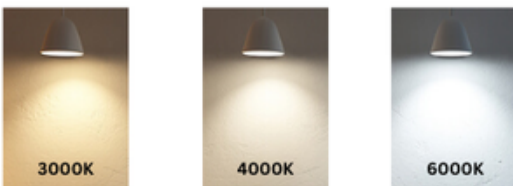

SKU	LUMENS	WATT	DIMENSIONS	CUT OUT	CARTON QTY
TL-DL01-7007W-CCT	100lm/w @ 4000K	7W	Ø92x55mm	Ø70mm	50PCS
TL-DL01-9010W-CCT TL-DL01-9010W-CCT-5Y	100lm/w @ 4000K	10W	Ø115x60mm	Ø90mm	40PCS
ES-LDL02-11012W-CCT	100lm/w @ 4000K	12W	Ø140x65mm	Ø110mm	40PCS
ES-LDL02-15016W-CCT	100lm/w @ 4000K	16W	Ø190x70mm	Ø150mm	20PCS
ES-LDL02-18020W-CCT	100lm/w @ 4000K	20W	Ø225x85mm	Ø180mm	20PCS
ES-LDL02-20025W-CCT	100lm/w @ 4000K	25W	Ø235x85mm	Ø200mm	20PCS

Features

- Triac dimmable
- Input voltage range: 220-240V 50/60Hz
- Housing: aluminium & plastic
- Built in driver
- CCT selectable:3000K,4000K, 6000K
- CCT switch on rear
- Diffuser: frosted PC
- Polyamide body with latest heat dissipation technology
- Power factor: 0.9
- Ambient temperature:-20°C~+40°C
- High efficiency SMD LED chips 100lm/w
- IC-4
- Flex & plug: 1m
- CRI ≥80 and good stability over lifetime
- Quick and simple installation, with flex and plug
- IP44 below ceiling
- 3 years warranty option for 90mm
- 5 years warranty 90mm to 180mm

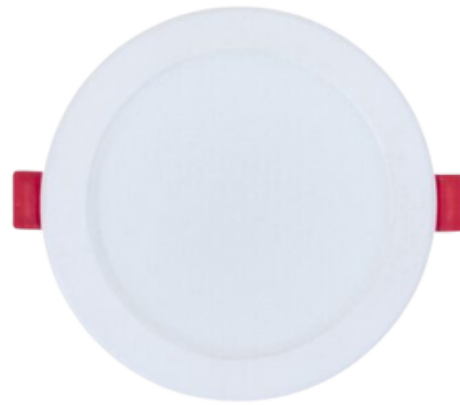

Dimensions

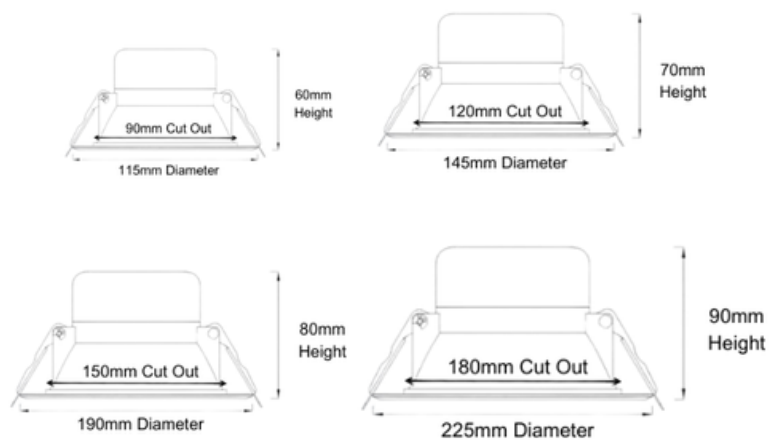

Standards

- IEC/AS/NZS 60598.1
- IEC/AS/NZS 60598.2.1
- IEC/AS/NZS 60598.2.2
- IEC/AS/NZS CISPR 15

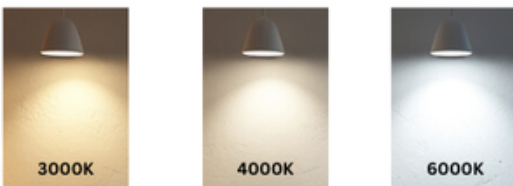

SKU	LUMENS	WATT	DIMENSIONS	CUT OUT	CARTON QTY
ES-DL01-9010W-CCT	90lm/w @ 4000K	10W	Ø115x60mm	Ø90mm	40PCS
ES-DL01-9010W-CCT-5Y	90lm/w @ 4000K	10W	Ø115x60mm	Ø90mm	40PCS
ES-LDL01-12012W-CCT	90lm/w @ 4000K	12W	Ø145x70mm	Ø120mm	40PCS
ES-LDL01-15016W-CCT	90lm/w @ 4000K	16W	Ø190x80mm	Ø150mm	20PCS
ES-LDL01-18020W-CCT	90lm/w @ 4000K	20W	Ø225x90mm	Ø180mm	20PCS

Features

- LED dimmable low glare Tri-CCT downlights
- Input voltage: 220-240V AC
- Inbuilt constant current LED driver included
- Housing & heatsink: plastic & aluminium
- Diffuser: PC
- Tri-CCT (3000K/ 4000K/ 6000K) in one fitting
- Rear switch
- CRI: ≥80
- IC-4:LS-COMET05 & LS-COMET06
- Power factor: 0.9
- Beam angle: 60 deg
- Flex & plug: 1m
- Ambient temperature: -20 to 40°C
- Suitable for dimming
- Suitable for 2-way switching
- Quick and simple installation, with flex and plug
- IP20 below ceiling (IP54 for front face only)
- 3 years warranty

Standards

- IEC/AS/NZS 60598.1
- IEC/AS/NZS 60598.2.1
- IEC/AS/NZS 60598.2.2
- IEC/AS/NZS CISPR 15

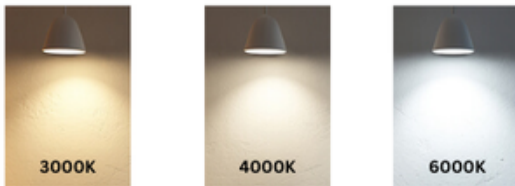

Dimensions

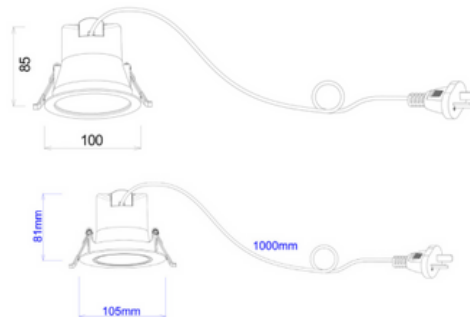

SKU	LUMENS	WATT	DIMENSIONS	CUT OUT	CARTON QTY
LS-COMET05	90lm/w @ 4000K	9W	Ø100x85mm	Ø90mm	45PCS
LS-COMET06	90lm/w @ 4000K	9W	Ø100x85mm	Ø90mm	45PCS
LS-COMET07	90lm/w @ 4000K	9W	Ø105x85mm	Ø90mm	45PCS
LS-COMET08	90lm/w @ 4000K	9W	Ø105x85mm	Ø90mm	45PCS

Features

- LED dimmable anti-glare Tri-CCT downlights
- Input voltage: 220-240V AC 50Hz
- Inbuilt constant current LED driver included
- Housing & heatsink: plastic & aluminium
- Diffuser: PC
- Tri-CCT (3000K/ 4000K/ 5700K) in one fitting
- Rear switch
- CRI: ≥80
- IC-4
- Power factor: 0.9
- Beam angle: 60 deg
- Flex & plug: 1m
- Ambient temperature: -20 to 40°C
- Suitable for dimming
- Suitable for 2-way switching
- Quick and simple installation, with flex and plug
- IP54 (indoor Use Only)
- 3 years warranty
- 50000 Hours lifespan



Dimensions

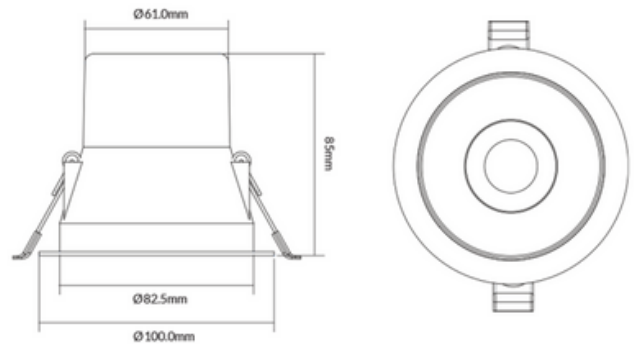

Standards

- IEC/AS/NZS 60598.1
- IEC/AS/NZS 60598.2.1
- IEC/AS/NZS 60598.2.2
- IEC/AS/NZS CISPR 15

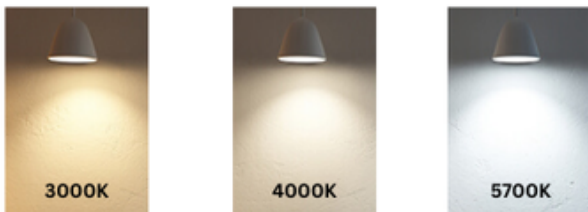

SKU	LUMENS	WATT	DIMENSIONS	CUT OUT	CARTON QTY
LS-VBLDL-800-1-CCT	90lm/w @ 4000K	9W	Ø100x85mm	Ø85-90mm	45PCS
LS-VBLDL-800-4-CCT	90lm/w @ 4000K	9W	Ø100x85mm	Ø85-90mm	45PCS

Features

- Input voltage: 220-240V AC 50/60Hz
- External constant current LED driver included
- Housing & heatsink: plastic & aluminium
- Diffuser: Opal PC
- Faceplate: PBT
- Power factor: 0.9
- Tri-CCT (3000K/ 4000K/ 5700K) in one fitting
- CCT switch on driver
- LED chips: SMD2835
- CRI: ≥80
- Flex & plug: 600mm
- Ambient temperature: -20 to 40°C
- Suitable for dimming
- Suitable for 2-way switching
- Suitable for use with sensor
- 3 years warranty



Dimensions

Standards

- IEC/AS/NZS 60598.1
- IEC/AS/NZS 60598.2.1
- IEC/AS/NZS 60598.2.2
- IEC/AS/NZS CISPR 15

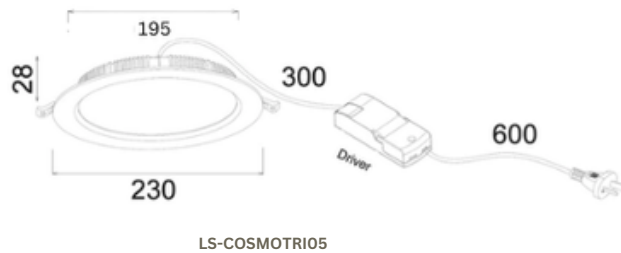
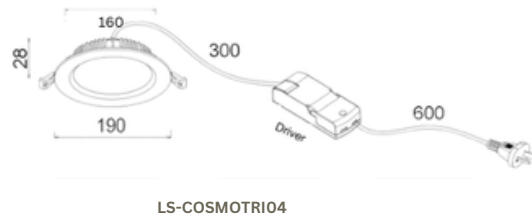
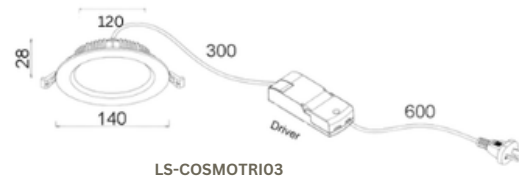

SKU	LUMENS	WATT	DIMENSIONS	CUT OUT	CARTON QTY
LS-COSMOTRI03	90lm/w @ 4500K	15W	Ø140x28mm	Ø120mm	30PCS
LS-COSMOTRI04	90lm/w @ 4500K	20W	Ø190x28mm	Ø160mm	20PCS
LS-COSMOTRI05	90lm/w @ 4500K	25W	Ø230x28mm	Ø195-205mm	20PCS

Features

- LED UFO style high bays
- Input voltage range: 100-277V AC 50/60Hz
- Constant current LED driver inbuilt
- Housing & heatsink: Die-casting ADC12
- Anti-UV, transmittance > 94%
- Power factor: ≥0.95
- CRI: 80
- Flex & plug: 1.2m
- Ambient temperature: -35 to 50°C
- Dimmable & 5700K ideally design for high ceiling
- Suitable for 2-way switching
- 5 years warranty
- 50,000Hrs Life span
- High Strength Polycarbonate Lens 120 Deg
- Optional 3years Labour Warranty



Dimensions

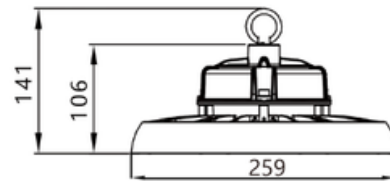

ES-HB01-100W-5700K

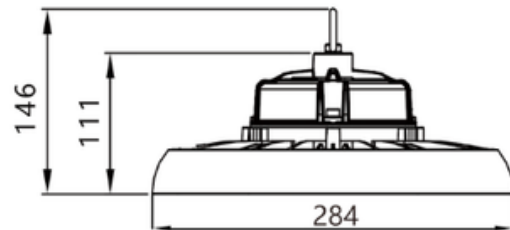

ES-HB01-150W-5700K

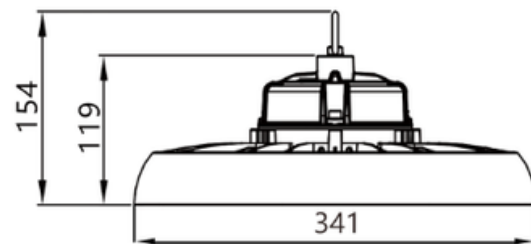

ES-HB01-200W-5700K

Standards

- IEC/AS/NZS 60598.1
- IEC/AS/NZS 60598.2.1
- IEC/AS/NZS CISPR 15
- IEC/AS/NZS 61347.2/613747.1

Product Certificate

- UL/ETL/DLC/TUV/CB/ENEC/CE/SAA/FCC/RoHS/CCC

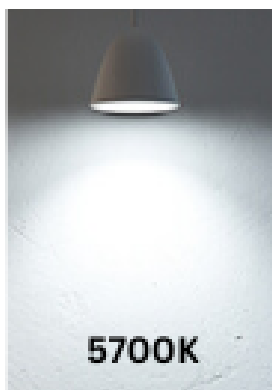

SKU	LUMENS	WATT	DIMENSIONS	CCT	CARTON QTY
ES-HB01-100W-5700K	15000LM	100W	Ø259x114mm	5700k	1PCS
ES-HB01-150W-5700K	22500LM	150W	Ø284x146mm	5700k	1PCS
ES-HB01-200W-5700K	30000LM	200W	Ø341x154mm	5700k	1PCS
ES-HB01-150W-5700K- Sensor	22500LM	150W	Ø284x146mm	5700k	1PCS
ES-HB01-200W-5700K- Sensor	30000LM	200W	Ø341x154mm	5700k	1PCS

Features

- LED UFO style high bays
- Input voltage range: 100-277V AC 50/60Hz
- Constant current LED driver inbuilt
- Housing & heatsink: Die-casting ADC12
- Anti-UV, transmittance > 94%
- Power factor: ≥0.95
- CRI: 80
- Flex & plug: 1.2m
- Ambient temperature: -35 to 50°C
- Dimmable
- 5700K or 3 Power & 3CCT 3/4/5.7k
- Suitable for 2-way switching
- 5 years warranty
- 50000Hrs Life span
- High Strength Polycarbonate Lens 110 Deg



Dimensions

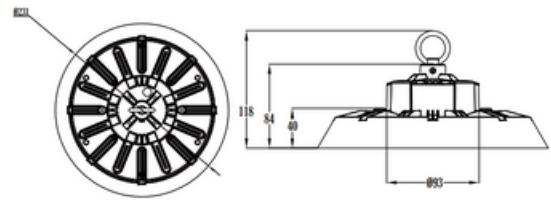

ES-HB02-100W-5700K

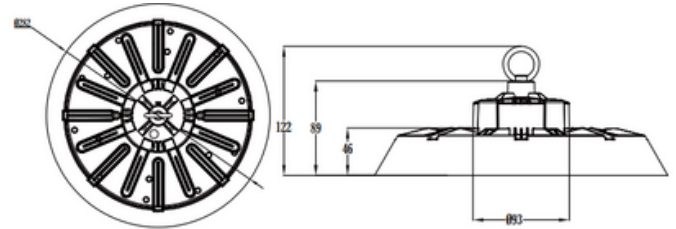

ES-HB02-150W-5700K

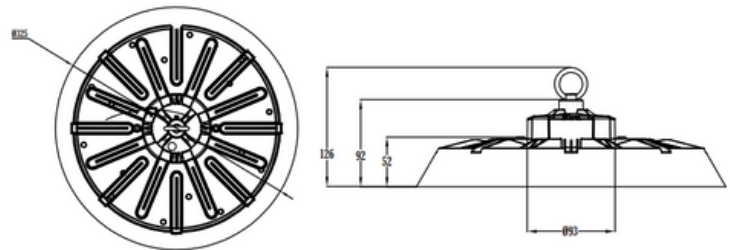

ES-HB02-200W-5700K

Standards

- IEC/AS/NZS 60598.1
- IEC/AS/NZS 60598.2.1
- IEC/AS/NZS CISPR 15
- IEC/AS/NZS 61347.2/613747.1

Product Certificate

UL/ETL/DLC/TUV/CB/ENEC/CE/SAA/FCC/RoHS/CCC



5700K



3000K



4000K



5700K

SKU	LUMENS	WATT	DIMENSIONS	CCT	CARTON QTY
ES-HB02-100W-5700K	15000LM	100W	Ø231x118mm	5700k	1PCS
ES-HB02-150W-5700K	22500LM	150W	Ø282x122mm	5700k	1PCS
ES-HB05-200W-5700K	30000LM	200W	Ø325x126mm	5700k	1PCS
ES-HB02-150W-CCT	22500LM @ 4K	150W	Ø282x122mm	3/4/5.7K	1PCS
ES-HB02-200W-CCT	30000LM @ 4K	200W	Ø325x126mm	3/4/5.7K	1PCS

Features

- Input voltage range: 220-240V AC 50/60Hz
- Housing & heatsink: Aluminum & PC
- Power factor: ≥0.9
- CRI: 80
- 3CCT: 3000/4000/5700K OR 3000/4000/6000K
- Flex & plug: 1.2m
- Ambient temperature: -10 to 40°C
- Suitable for 2-way switching
- 3 years warranty
- Beam Angle: 120 Deg
- Sidelit

Standards

IEC/AS/NZS 60598.1
 IEC/AS/NZS 60598.2.1
 IEC/AS/NZS CISPR 15

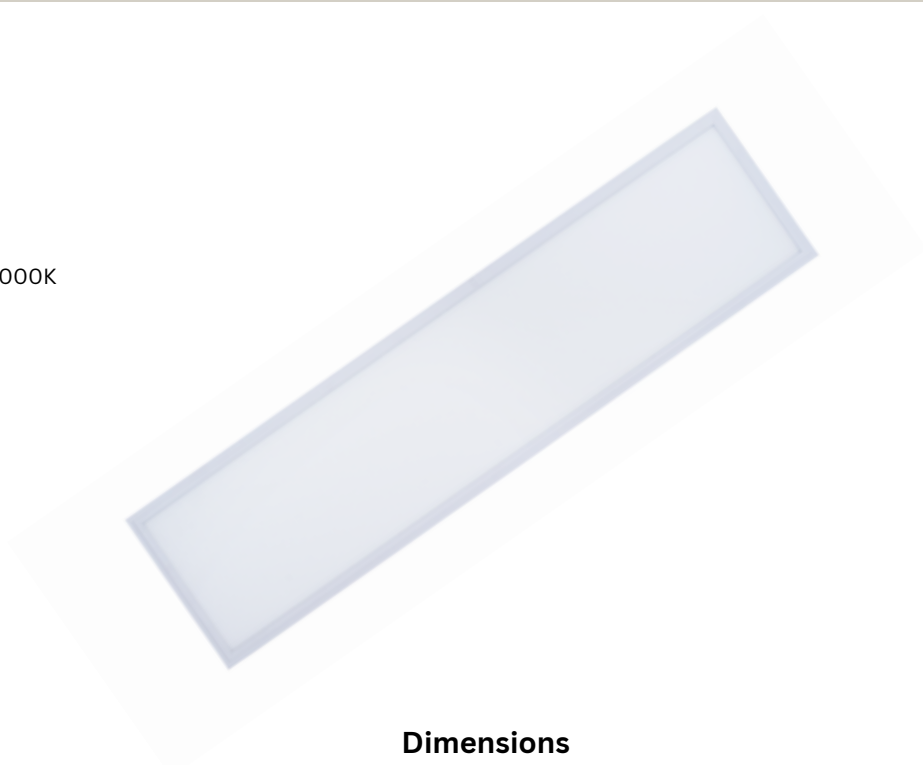

Dimensions



ES-PL01-30120-32W-CCT-SIDE

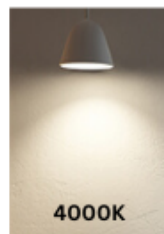

ES-PL01-30120-36W-CCT-SIDE



SKU	LUMENS	WATT	DIMENSIONS	CCT	CARTON QTY
ES-PL01-30120-32W-CCT-SIDE	3600LM@4000K	32W	1195x295mm	3000K-4000K-5700k	5PCS
ES-PL01-30120-36W-CCT-SIDE	3240LM@4000K	36W	1195x295mm	3000K-4000K-6000k	8PCS

Features

- Input voltage range: 220-240V AC 50/60Hz
- Housing & heatsink: Aluminum & PC
- Power factor: ≥0.9
- CRI: 80
- 3CCT: 3000/4000/6000
- Flex & plug: 1m
- Ambient temperature: -10 to 40°C
- Suitable for 2-way switching
- 5 years warranty
- 50000Hrs Life span
- Beam Angle: 120 Deg
- Backlit



Standards

IEC/AS/NZS 60598.1
 IEC/AS/NZS 60598.2.1
 IEC/AS/NZS CISPR 15

Dimensions

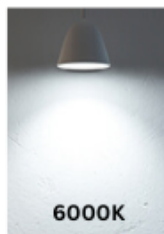

OR

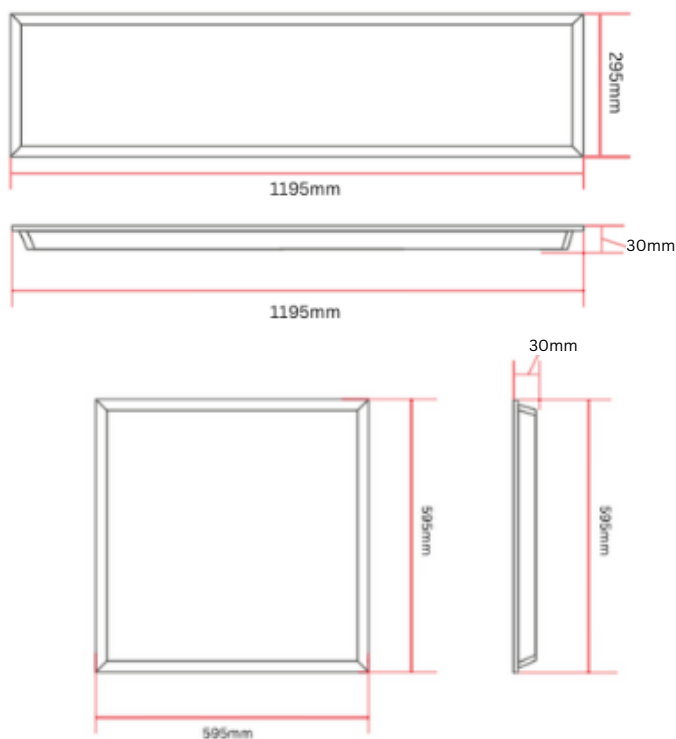
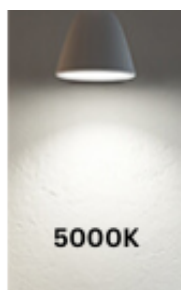

SKU	LUMENS	WATT	DIMENSIONS	CCT	CARTON QTY
ES-PL02-30120-36W-CCT-5Y	3600LM@4000K	36W	1195x295mm	3000K-4000K-6000k	5PCS
ES-PL02-6060-36W-CCT-5Y	3600LM@4000K	36W	1195x295mm	3000K-4000K-6000k	5PCS
ES-PL02-30120-36W-5000K-5Y	3600LM	36W	1195x295mm	5000K	5PCS

Features

- Input voltage range: 100-277V AC 50/60Hz
- Constant current LED driver inbuilt
- Housing & heatsink: Die-casting ADC12
- Anti-UV, transmittance > 94%
- Power factor: ≥0.95
- CRI: 80
- Flex & plug: 1.2m
- Ambient temperature: -35 to 45°C
- 5000K or 3000K
- Suitable for 2-way switching
- 5 years warranty
- 50000Hrs Life span
- 120 Deg beam angle
- IP66 IK08
- 50W Sensor optional



Standards

IEC/AS/NZS 60598.1
 IEC/AS/NZS 60598.2.1
 IEC/AS/NZS CISPR 15

Product Certificate

UL/ETL/DLC/TUV/CB/ENEC/CE/SAA/FCC/RoHS/CCC



OR

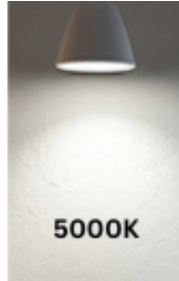

Dimensions

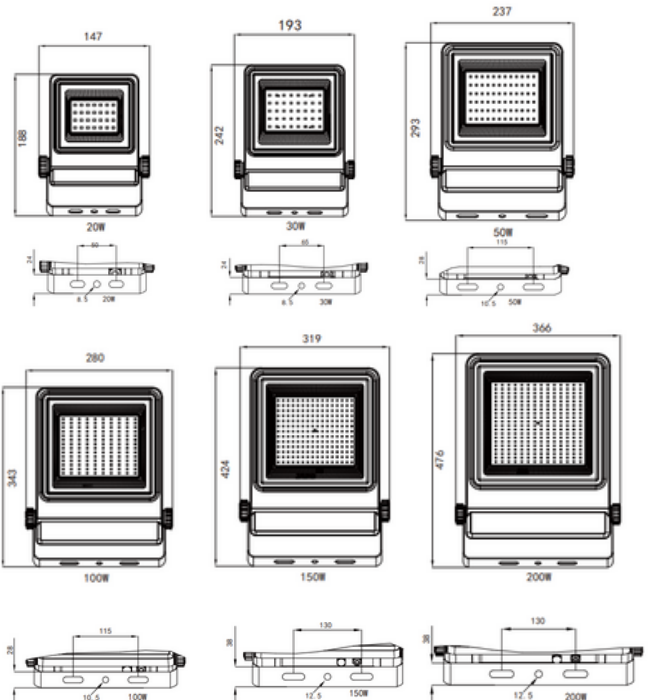

SKU	LUMENS	WATT	DIMENSIONS	CCT	CARTON QTY
ES-FL01-20W	2400LM	20W	188x147mm	3000K OR 5000k	1PCS
ES-FL01-30W	3600LM	30W	242x193mm	3000K OR 5000k	1PCS
ES-FL01-50W	6000LM	50W	293x237mm	3000K OR 5000k	1PCS
ES-FL01-100W	12000LM	100W	343x280mm	3000K OR 5000k	1PCS
ES-FL01-150W	18000LM	150W	424x319mm	3000K OR 5000k	1PCS
ES-FL01-200W	24000LM	200W	476x366mm	3000K OR 5000k	1PCS

Features

- Input voltage range: 220-240V AC 50/60Hz
- Housing & heatsink: SPCC+PC
- Anti-UV, transmittance > 94%
- Power factor: ≥0.95
- CRI: 80
- Dimmable
- Ambient temperature: -20 to 40°C
- 3CCT: 3000/4000/5700K
- Suitable for 2-way switching
- 3 years warranty
- 50000Hrs Life span
- 120 Deg beam angle
- IP44

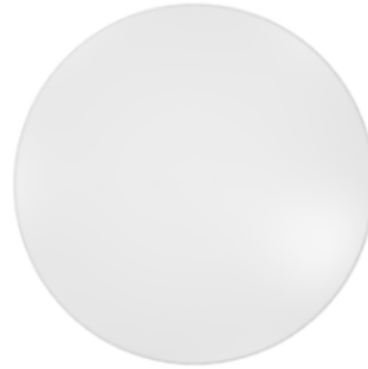

Standards

IEC/AS/NZS 60598.1
 IEC/AS/NZS 60598.2.1
 IEC/AS/NZS CISPR 15

Dimensions

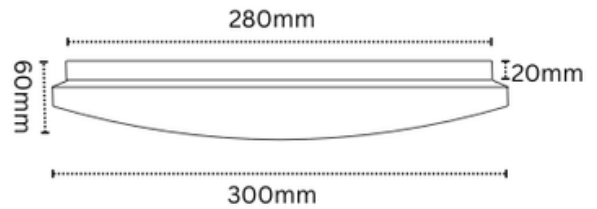

ES-Ost-15W-D300

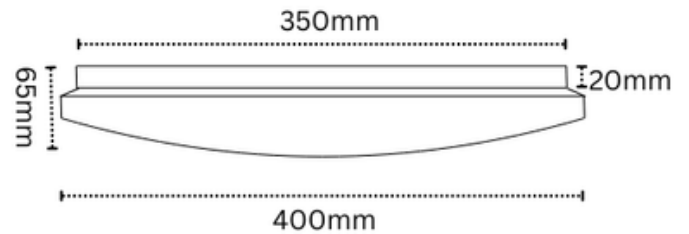

ES-Ost-25W-D400

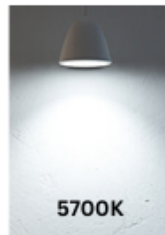
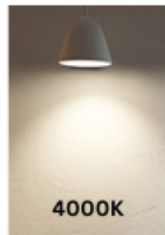

SKU	LUMENS	WATT	DIMENSIONS	CCT	CARTON QTY
ES-Ost-15W-D300	1500LM	15W	Ø300mmx60mm	3000K/4000K/5700k	18PCS
ES-Ost-25W-D400	2500LM	25W	Ø400mmx65mm	3000K/4000K/5700k	12PCS

Features

- COB technology offer uniform light distribution
- Input voltage range: 100-240V AC
- 320 LEDs per meter
- With Power supply
- Power factor: ≥ 0.95
- CRI: 90
- Ambient temperature: -20 to 40°C
- 3000K or 5000K
- 3 years warranty
- 50000Hrs Life span
- 120 Deg beam angle



Standards

IEC/AS/NZS 61558.2.16:2010 inc A1-3
 IEC/AS/NZS 3112:2017
 IEC/AS/NZS CISPR 32:2015



Dimensions



OR

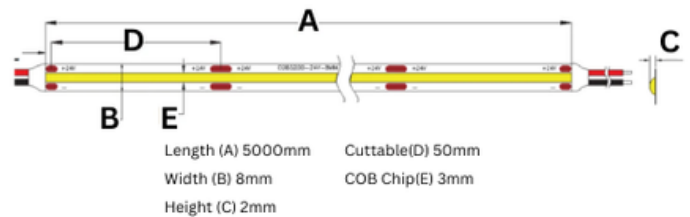
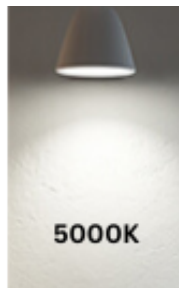

SKU	LUMENS	WATT	DIMENSIONS	CCT	CARTON QTY
ES-SL01-COB-320D-7W-3000K	540LM/M	7W/M	5000mmx8mm	3000K	20PCS
ES-SL01-COB-320D-7W-5000K	540LM/M	7W/M	5000mmx8mm	5000K	20PCS

Features

- COB technology offer uniform light distribution
- Fit universal 1 circuit track
- Input voltage range: 220-240V AC
- Power factor: ≥0.95
- CRI: 90
- Ambient temperature: -20 to 45°C
- 3000K in Black or 4000K in White
- 3 years warranty
- 24 Deg beam angle
- Rotated up to 350° and adjusted vertically up to 90°



Standards

IEC/AS/NZS 60598.1
 IEC/AS/NZS 60598.2.1
 IEC/AS/NZS CISPR 15



OR



Dimensions

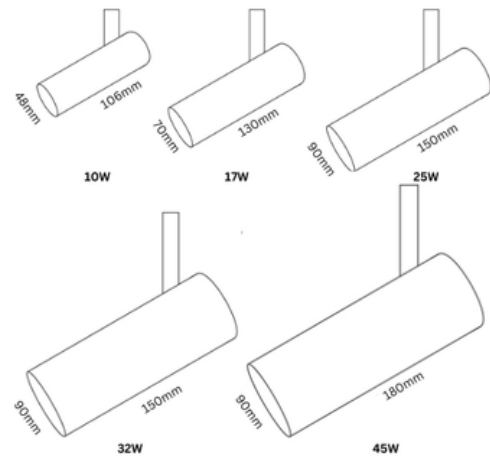

SKU	LUMENS	WATT	DIMENSIONS	CCT	CARTON QTY
ES-TL01-10W	900LM	10W	106x48mm	3000K in Black 4000K in White	40PCS
ES-TL01-17W	1530LM	17W	130mmx70mm	3000K in Black 4000K in White	40PCS
ES-TL01-25W	2250LM	25W	150mmx90mm	3000K in Black 4000K in White	20PCS
ES-TL01-32W	2880LM	32W	150mmx90mm	3000K in Black 4000K in White	20PCS
ES-TL01-45W	4050LM	45W	180mmx90mm	3000K in Black 4000K in White	16PCS

Features

- COB technology offer uniform light distribution
- Fit universal 1 circuit track
- Input voltage range: 220-240V AC 50/60Hz
- Built in Driver
- Power factor: ≥ 0.95
- CRI: 80
- Ambient temperature: -20 to 45°C
- 3CCT 3000/4000/6000K
- 3 years warranty
- 23 Deg beam angle
- Rotated up to 350° and adjusted vertically up to 90°



Standards

IEC/AS/NZS 60598.1
 IEC/AS/NZS 60598.2.1
 IEC/AS/NZS CISPR 15

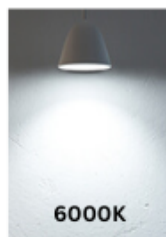

Dimensions

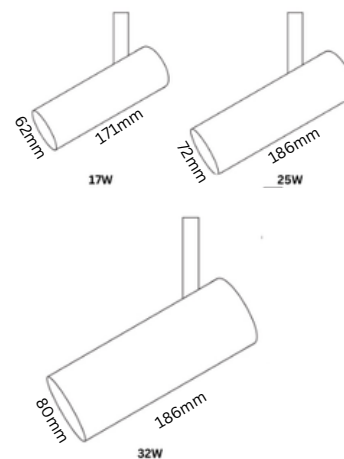

SKU	LUMENS	WATT	DIMENSIONS	CCT	CARTON QTY
TL-TL01-17W-CCT	1530LM	10W	171x62mm	3000/4000/6000K	40PCS
TL-TL01-25W-CCT	2250LM	17W	186mmx72mm	3000/4000/6000K	40PCS
TL-TL01-32W-CCT	2880LM	25W	186mmx80mm	3000/4000/6000K	20PCS

Features

- COB technology offer uniform light distribution
- Fit universal 1 circuit track
- Input voltage range: 220-240V AC 50/60Hz
- With Power supply
- Power factor: ≥0.95
- CRI: 80
- Ambient temperature: -20 to 45°C
- 6000K OR 3000K
- 3 years warranty
- 180 Deg beam angle
- IP54

Standards

IEC/AS/NZS 60598.1
 IEC/AS/NZS 60598.2.1
 IEC/AS/NZS CISPR 15



OR

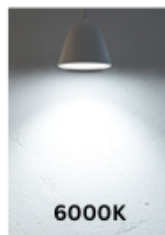

SKU	LUMENS	WATT	DIMENSIONS	CCT	CARTON QTY
TL-SWL01-13W-6000K	1300LM	13W	171x62mm	6000K	10PCS
TL-SSWL01-13W-6000K	1300LM	13W	186mmx72mm	6000K	10PCS
TL-DWL01-26W-6000K	2600LM	26W	186mmx80mm	6000K	10PCS
TL-DSWL01-26W-6000K	2600LM	26W	186mmx80mm	6000K	10PCS
TL-DSWL01-26W-3000K	2600LM	26W	186mmx80mm	3000K	10PCS
LS-CE.FL20S30W	3000LM	30W	186mmx80mm	6000K	10PCS

Features

- Input voltage: 220-240V AC 50/60Hz
- Inbuilt driver included
- Diffuser: PC (white)
- Material: steel & PC
- High power factor: ≥ 0.9
- Tri-CCT (3000K/ 4000K/ 5700K) in one fitting
- Internal switch (under diffuser)
- LED chips: SMD2835
- CRI: >80
- Ambient temperature: -20 to 40°C
- Suitable for 2-way switching
- Suitable for use with 3 wire sensor
- 3 years warranty
- Large terminal block for easy installation



Standards

IEC/AS/NZS 60598.1
 IEC/AS/NZS 60598.2.1
 IEC/AS/NZS CISPR 15

Dimensions

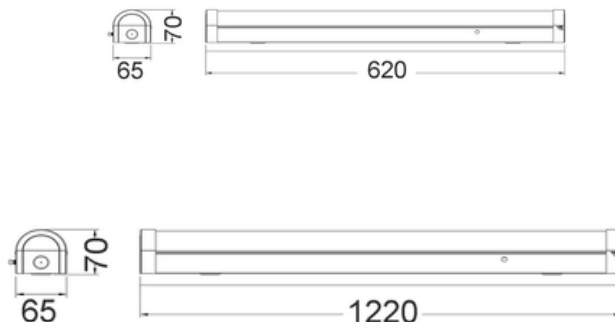

SKU	LUMENS	WATT	DIMENSIONS	CCT	CARTON QTY
LS-BAT001	1100LM/2200LM @4000K	10W/20W	620x70x65mm	3000/4000/5700K	9PCS
LS-BAT002	2200LM/4400LM @4000K	20W/40W	1220x70x65mm	3000/4000/5700K	9PCS

Features

- Interior LED Surface Mounted Dimmable Tri-CCT Battens (Wide)
- Input voltage: 220-240V AC 50/60Hz
- Inbuilt driver included
- Diffuser: PC (white)
- Housing: powder coated aluminium
- Heatsink: aluminium
- High power factor: ≥ 0.9
- Tri-CCT (3000K/ 4000K/ 5000K) in one fitting
- Internal switch (under diffuser)
- Central hole in mounting plate
- LED chips: SMD2835
- CRI: >80
- Ambient temperature: -20 to 40°C
- Suitable for dimming with most trailing edge dimmers Suitable for 2-way switching
- Suitable for use with 3 wire Microwave & Motion sensors



Standards

IEC/AS/NZS 60598.1
 IEC/AS/NZS 60598.2.1
 IEC/AS/NZS CISPR 15

Dimensions

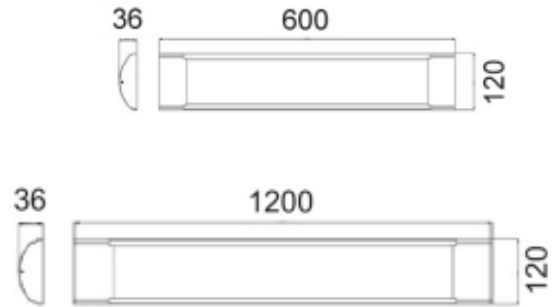

SKU	LUMENS	WATT	DIMENSIONS	CCT	CARTON QTY
LS-RAZORDMW01	1700LM @4000K	18W	600x120x36mm	3000/4000/5000K	10PCS
LS-RAZORDMW02	3400LM @4000K	36W	1200x120x36mm	3000/4000/5000K	10PCS

Features

- High-powered long-life LED
- High-Temperature LiFePO4 Lithium Battery
- Easy-Connect installation
- Complete with Decals
- 24m viewing distance
- Fully Compliant with AS2293
- Switchable with Cleverfit



White finish

Standards

AS/NZ 2293
AS/NZS 60598.1
EMC

Classification

C0 E2 C90 E2



Black finish

Dimension (L x W x H) 355mm x 80mm x 215mm

Features

- Recessed Mount Emergency Luminaire
- High-Temperature LiFePO4 Lithium Battery
- High-powered long-life LED
- Complete with Flex and Plug
- Emergency classification D40
- Fully compliant with AS2293

Standards

AS/NZ 2293
AS/NZS 60598.1
EMC

Classification

C0 D40 C90 D40



White Finish



Black Finish

Ceiling Hole Cut Out 70mm(S), 75-135mm(L)

Dimension (L x W x H)

228mm x 43mm x 27mm - Control Pack
84mm(S), 145mm(L) - Head Diameter

Optional Budget Control Products

Classification

EMSTAR

C0 D32 C90 D32



Classification

LS-EXWAY

C0 D8 C90 D6.3



SKU	BATTERY	WATT	DIMENSIONS	COLOUR	CARTON QTY
LS-EXLEDL	High-Temp LiFePO4 Lithium Battery	3W	355mm x 80mm x 215mm	White/Black	5PCS
LS-EMLITEL	High-Temp LiFePO4 Lithium Battery	3W	70mm(S), 75-135mm(L) Cut Out	White/Black	20PCS
LS-EXWAY	High-Temp LiFePO4 Lithium Battery	4W	365mm x 80mm x 230mm	White	5PCS
LS-EMSTAR	High-Temp LiFePO4 Lithium Battery	2W	70mm(S), 75-135mm(L) Cut Out	White	20PCS

Features

Clipsal equivalent 755PSMA4
 Brooks equivalent EIB146RC
 PSA equivalent LIF2800/2

Features

- Interconnected
- Battery Back up
- Hush function
- Self-test
- Button for test/hush function
- 240 Volt
- Battery Back up



R240

Standards

AS 3786 : 2014 / amdt 2:2018

Classification: SAI

Features

Clipsal equivalent 755LPSMA4
 Brooks equivalent EIB650iRF
 PSA equivalent LIF10YPEW

Features

- Interconnected
- Wireless interconnection
- 10 year sealed lithium battery
- Hush Function
- Self-test
- Local alarm
- Button for test/hush



R10RF

Standards

AS 3786 : 2014 / amdt 2:2018

SKU	TYPE	DIMENSIONS	COLOUR	CARTON QTY
LS-R240	Hard Wire	140mm x 39mm	White	10PCS
LS-R10RF	Wireless	140mm x 55mm	White	10PCS
LS-R240RC	Hard Wire	140mm x 55mm	White	10PCS
LS-R10	Stand Alone	140mm x 39mm	White	10PCS

Features

- Lumileds chips, high brightness, low light decay & long lifetime
- International driver brand MW/SOSEN, overheat protection, high convert efficiency, high PF & surge protection, (1-10V,DALI2.0)
- Die-casting technology with ADC12, excellent thermal management and balance the internal & external temperature, reduce chip Tj and light decay.
- Optical UV resistant PC lens with 94% light transmittance, IK08. Light Distribution: 10°/15°/25°/45°/60°/90°/Asymmetrical 60°
- Bracket Installation, operation temperature: -35°C- +50°C
- IP66
- IK08, Optional IK10
- Life Span: 50000Hrs
- Input Voltage: AC100-277V 50/60Hz
- Output Voltage: DC48V
- Customise CCT: 3000-6500K
- Customise Beam Angle 10/25/45/60/90/Asymmetrical 60°
- Customise CRI: Ra>70,80,90



Standards

UL/ETL/DLC/TUV/CB/ENEC/CE/SAA/FCC/RoHS/CQC

Dimension

Photometry

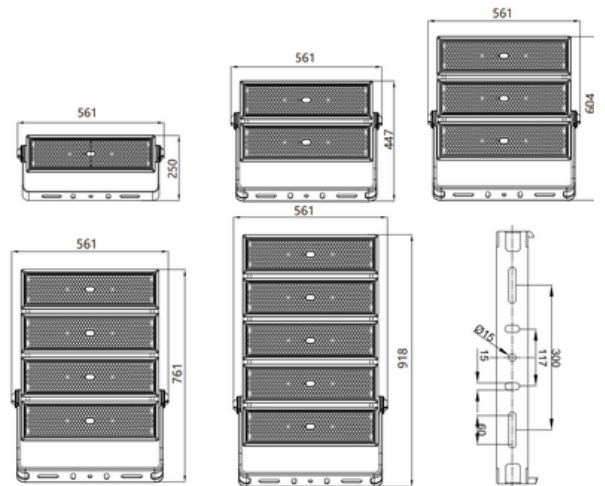
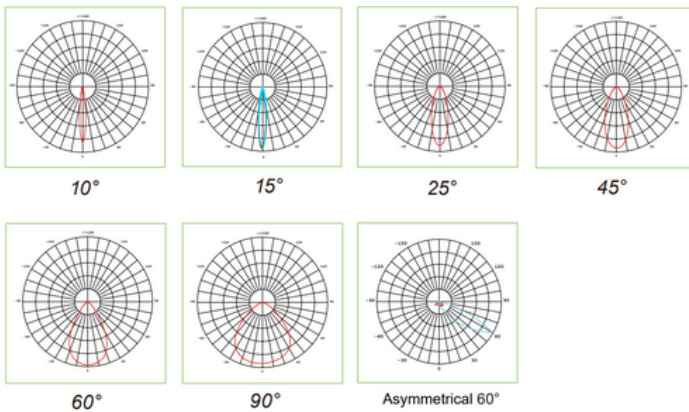

SKU	WATT	DIMENSIONS	CCT	CARTON QTY
ES-HM01-250W-5000K	250W	250mm x 561mm	5000K	1PCS
ES-HM01-500W-5000K	500W	447mm x 561mm	5000K	1PCS
ES-HM01-750W-5000K	750W	604mm x 561mm	5000K	1PCS
ES-HM01-1000W-5000K	1000W	761mm x 561mm	5000K	1PCS
ES-HM01-1250W-5000K	1250W	918mm x 561mm	5000K	1PCS

Features

- Lumileds chips, high brightness, low light decay & long lifetime
- International driver brand MW/SOSEN, overheat protection, high convert efficiency, high PF & surge protection, (1-10V,DALI2.0)
- Die-casting technology with ADC12, excellent thermal management and balance the internal & external temperature, reduce chip Tj and light decay.
- Optical UV resistant PC lens with 94% light transmittance, IK08. Light Distribution: T2-M, T3-M
- Bracket Installation, operation temperature: -35°C- +50°C
- IP66, 10KV
- IK08, Optional IK10
- Life Span: 50000Hrs
- Input Voltage: AC100-277V 50/60Hz
- Output Voltage: DC42V
- Plug in light sensor
- Customise CCT: 3000-6500K
- Customise Bean Angle: T2-M,T3-M
- Customise CRI: Ra>70,80

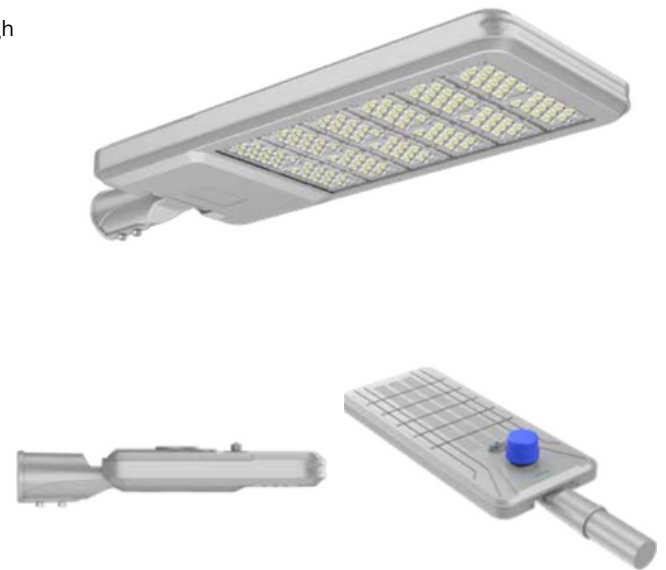

Standards

UL/ETL/DLC/TUV/CB/ENEC/CE/SAA/FCC/RoHS/CQC

Dimension

Photometry

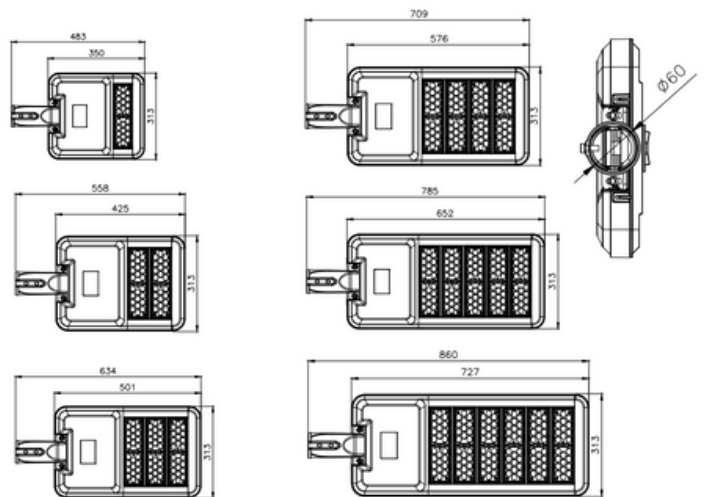
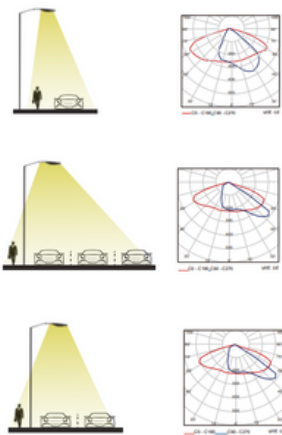

SKU	WATT	DIMENSIONS	CCT	CARTON QTY
ES-STL01-50W-5000K	50W	483mm x 313mm	5000K	1PCS
ES-STL01-100W-5000K	100W	558mm x 313mm	5000K	1PCS
ES-STL01-150W-5000K	150W	634mm x 313mm	5000K	1PCS
ES-STL01-200W-5000K	200W	709mm x 313mm	5000K	1PCS
ES-STL01-250W-5000K	250W	785mm x 313mm	5000K	1PCS
ES-STL01-300W-5000K	300W	860mm x 313mm	5000K	1PCS



SHOP NOW

WWW.EAGLESQUARE.COM.AU

